



Town of Yarmouth
Sidewalk & Curb Program
2023 Season

April 11, 2023

Re: Town of Yarmouth Tender – Sidewalk and Curb Program – 2023 Construction Season

To whom it may concern:

The Town of Yarmouth is requesting unit contract prices for the construction of new and replacement concrete sidewalks and curbs on various streets within the Town of Yarmouth for the 2023 construction season.

Items required for pricing are as follows:

- a) Maintenance work will involve the replacement of complete sections of concrete sidewalk and curb, as well as replacement of individual slabs and sections of curb.
- b) All units used for pricing are metric.
- c) Traffic control shall be provided by the contractor in accordance with the Nova Scotia Department of Labour's Temporary Workplace Traffic Control Manual, latest edition.
- d) The tender closing date will be on **Tuesday, April 25, 2023, at 3:00 p.m.** Sealed tenders are to be returned to the office of the Chief Administrative Officer, 400 Main Street, Yarmouth, Nova Scotia, B5A 1G2 in a sealed envelope clearly marked **Tender – Town of Yarmouth, Concrete Sidewalk & Curbs 2023 Season.** Late tenders will not be considered and will be returned unopened. Fax or telephone bids will not be accepted.
- e) The lowest or any tender may not necessarily be accepted. Such things as past performance, quality of work, references and start/completion dates will be taken into consideration when awarding the contract.

Sincerely,



Chad E. LeBlanc
Manager of Public Works

CEL/slf

Enclosures

c: Mr. Jeff Gushue, CAO
file

TENDER PRICES - 2023 CONCRETE
SIDEWALKS & CURBS - REPLACEMENT

Tender prices for the replacement of concrete sidewalks and curbs in accordance with the attached specification and drawings are submitted below:

		UNIT PRICE
1.	Concrete sidewalk as per drawing #1 (width varies from 1.2m to 3.65m)	\$ _____ / square meter
2(a)	Concrete sidewalk - curb combination as per drawing #2 (300mm width X 1m in length)	\$ _____ / linear meter
(b)	Additional width of 2(a) varies between 300mm and 3m	\$ _____ / square meter
3(a)	Concrete Island as per drawing #5 (minimum width 1.2m)	\$ _____ / linear meter
(b)	Additional width of island between 0 and 2.4m	\$ _____ / square meter
4.	Stamped & Colored Concrete sidewalk (to match surrounding sidewalk on Water Street grey in color)	\$ _____ / square meter
5.	Stamped & colored concrete sidewalk (remove existing brickwork, dowel into sides & bottom of adjacent concrete slabs on Main Street)	\$ _____ / square meter
6.	Exposed aggregate finish concrete sidewalk (red)	\$ _____ / square meter
7.	Concrete curb, type E, N.S. Department of Transportation and Public Work as per drawing #4	\$ _____ / linear meter

Contractor's Name: _____

SIDEWALK & CURB REPLACEMENT

- | | | |
|-----|--|--|
| 8. | Concrete curb/gutter combination type A
N.S. Department of Transportation and
Public Works as per drawing #3 | \$ _____ / linear meter |
| 9. | Semi-mountable concrete curb/gutter
combination as per drawing #8 | \$ _____ / linear meter |
| 10. | 150mm thick concrete sidewalk &
driveway ramps as per drawing #6 | \$ _____ / square meter |
| 11. | 150mm thick reinforced concrete sidewalk and
driveway ramps | \$ _____ / square meter |
| 12. | Patching 100mm thick concrete sidewalk | \$ _____ / square meter |
| 13. | Granular pit run (supply & place) | \$ _____ / metric tonne |
| 14. | Machine formed concrete curb Type E as per
drawing #4 | \$ _____ / linear meter |
| 15. | Machine formed concrete curb/gutter
combination as per drawing #3 | \$ _____ / linear meter |
| | | Minimum quantity of curbing
required for mobilization
_____ linear meter |
| 16. | Common Excavation
(including disposal of excess material) | \$ _____ / cubic meter |

****NOTE: H.S.T. is not to be included in unit prices.***

Contractor's Name: _____

TENDER PRICES - 2023 CONCRETE
SIDEWALKS & CURBS - NEW

Tender prices for the construction of new concrete sidewalks and curbs in accordance with the attached specifications and drawings are as submitted below:

		UNIT PRICE
1.	Concrete sidewalk as per drawing #1 (width varies from 1.2m to 3.65m)	\$ _____ / square meter
2(a)	Concrete sidewalk - curb combination as per drawing #2 (300mm in width X 1m in length)	\$ _____ / linear meter
(b)	Additional width of 2(a) varies between 300mm and 3.0m	\$ _____ / square meter
3(a)	Concrete Island as per drawing #5 (minimum width 1.2m)	\$ _____ / linear meter
(b)	Additional width of island between 0 and 2.4m	\$ _____ / square meter
4.	Stamped & Colored Concrete Sidewalk (cobblestone or brick imprint, Water Street)	\$ _____ / square meter
5.	Exposed aggregate finish concrete Sidewalk (red)	\$ _____ / square meter
6.	Concrete curb type E, N.S. Department of Transportation and Public Works as per drawing #4	\$ _____ / linear meter

Contractor's Name: _____

SIDEWALK & CURB - NEW

- | | | |
|-----|--|-------------------------|
| 7. | Concrete curb/gutter combination type
A N.S. Department of Transportation and
Public Works as per drawing #3 | \$ _____ / linear meter |
| 8. | Rolled concrete curb/gutter combination
as per drawing #9 (a)
Driveway crossing details drawing #9 (b) | \$ _____ / linear meter |
| 9. | 150mm thick concrete sidewalk
& driveway ramps as per drawing #6 | \$ _____ / square meter |
| 10. | 150mm thick reinforced concrete sidewalk
& driveway ramps. | \$ _____ / square meter |
| 11. | Granular pit run (supply & place) | \$ _____ / metric tonne |
| 12. | Machine formed concrete curb type E
as per drawing #4 | \$ _____ / linear meter |
| 13. | Machine formed concrete curb/gutter
combination as per drawing #3 | \$ _____ / linear meter |

Minimum quantity of curbing required
for mobilization
_____ linear meter

- | | | |
|-----|--|------------------------|
| 14. | Common Excavation
(including disposal of excess material) | \$ _____ / cubic meter |
|-----|--|------------------------|

****NOTE: H.S.T. is not to be included in unit prices.***

Contractor's Name: _____

Name of Contractor:

Business Address:

Phone Numbers:

office

fax

e-mail

Signature & Corporate Seal:

**Specifications for the Construction
of Concrete Curb & Sidewalks**

1.0 Sidewalks:

- (a) Concrete sidewalks shall be constructed by hand or mechanical means with 30 MPa concrete at 28 days, 6% air entrainment and 75 mm slump.
- (b) Gravel base shall be a minimum of 150 mm type 1 gravel compacted to 95% modified Proctor density and shall extend 150 mm outside of each edge of the concrete sidewalk.
- (c) Sidewalk slabs shall be 100 mm thick except at driveways and ramps where it shall be 150 mm thick.
- (d) Sidewalk slabs for commercial driveways and ramps shall be 150 mm thick reinforced with 150 X 150 - 6/6 welded wire mesh.
- (e) The sidewalk slab shall be done in one continuous pour with control joints extending to one quarter of the slab thickness at a maximum spacing of 1.5 meters. Control joints shall be completed by saw cutting within 24 hours of the concrete setting up. Tie bars shall be placed in the ends of sidewalk slabs to tie previously poured slabs to newly poured sidewalk slabs.
- (f) Concrete sidewalk shall have a broom finish (perpendicular to curb line) with a three inch wide border with a trowel finish.
- (g) A membrane curing compound shall be applied to the sidewalk surface - Sternson Clear Florseal or approved equal according to manufacturer's directions.
- (h) Full depth construction or isolation joints consisting of a minimum of 12 mm of compressible material shall be placed as follows:
 - (1) where sidewalk abuts curbs
 - (2) hydrants, valve boxes, service boxes, utility poles, etc.
 - (3) walls, buildings and other rigid structures
- (i) All sidewalks shall be sloped at 2% grade toward the top of the curb.
- (j) The surface of the concrete after texturing shall be within a 6mm deviation measured at any point along its length using a 3 meter long straight edge.
- (k) Cold weather protection shall be followed when the air temperature is expected to fall below 5°C.
- (l) Pedestrian ramps shall be installed at all intersections with a 1.5 meters low profile curb and a 300 mm taper on either end.

2.0 Curbs:

- (a) Concrete curbs and concrete curb gutter combination shall be constructed by hand or mechanical means.
- (b) Concrete shall be 30 MPa at 28 days, 6% air entrained and 75 mm slump. Slump may be decreased if mechanical extruders are used.
- (c) Concrete shall be placed on a minimum of 150 mm layer of type 1 gravel compacted to 95% modified Proctor density and extending 150 mm beyond the face of the curb or gutter and the back of the curb.
- (d) Concrete curb shall be done in a continuous pour with control joints of one quarter the thickness of the curb provided at 3.0 meter intervals. Control joints shall be installed by saw cutting. Tie bars shall be cast in the ends of the curb when the curb shall be extended with a fresh pour.
- (e) Concrete curbs shall have a broom finish along the length of the curb.
- (f) Where concrete sidewalk abuts the concrete curb, control joints shall match alternate sidewalk control joints.
- (g) Construction joints of compressible, non- degradable material extending through the full thickness of the curb shall be located as follows:
 - (1) where sidewalk and driveway ramps abut the curb.
 - (2) within 600 mm of the outside edges of catchbasin frames cast into concrete curbs.
- (h) Concrete curb and gutter cross section shall conform to type A curb Nova Scotia Department of Transportation specifications.
- (i) The finished surface of curbs and gutters shall be within a 6mm deviation measured at any point along the length of the curb with a 3 meter long straight edge.
- (j) compacted type 1 gravel shall be placed on the street side of the curb to finish asphalt grade and on the backside of the curb to 150mm below the top of the curb, extending to the edge of the curb trench.

3.0 Setting Out:

The Town's representative and the contractor's representative shall agree upon the areas where sidewalks are to be constructed. These areas shall be marked out at least one day ahead using a mutually agreed upon means.

4.0 Extra Materials:

Any area requiring extra material or fill shall be brought to the required grade by using granular pit run fill containing no rock larger than six inches in the largest dimension. Quantities shall be documented by weigh slips and submitted to the town's representative for verification.

5.0 Measurements for Billing Purposes:

All linear or square meter measurements shall be measured in place and verified by the Town's representative prior to payment of progress invoices. All measurements shall be taken with both the Town's representative and contractor's representative present.

6.0 Replacement of Existing Sidewalks & Curbs

The contractor is responsible for all cutting, removal, protection of services access points and restoration of the base to a compacted granular surface as per specifications for sidewalks.

All concrete slabs to be replaced shall be saw cut preferable at control joints. Asphalt shall be saw cut to the full depth of asphalt, based upon a 100 mm thickness, parallel to the face of the curb allowing a 600 mm working space. Tie bars shall be dowelled into the ends of the existing concrete curbs and into the edges of existing slabs prior to pouring new concrete.

Any manhole cover, riser, shut off top, valve box tops and risers necessary for a smooth surface shall be supplied by the Town and brought to finish grade by the contractor. Finish grade for such tops and covers shall be 0 to 6 mm below surrounding surfaces.

7.0 Finish Grading:

All finish grading between concrete curb and sidewalk shall be completed by the contractor. Finish grading on the inside of the sidewalk shall include a level 1.0 meter shoulder and then sloped at 3:1 ratio to match existing lawns. All loam will be supplied by the Town of Yarmouth and is to be picked up at the Public Works Yard at 227 Pleasant Street.

8.0 Surplus Material:

All surplus material shall be removed from the site and disposed of by the contractor, at the contractor's expense at a location approved by the Town's representative.

9.0 Protection of Newly Poured Concrete:

All barricading, rain cover and traffic protection is the responsibility of the contractor. Any damage as a result of vandalism to newly poured concrete surfaces shall be the responsibility of the contractor and any required replacement will be at the contractor's cost. Vehicular traffic shall be restricted from crossing the sidewalk after the concrete has been placed for a minimum period of three days or until the concrete has reached 75% of the specified 28 days compressive strength.

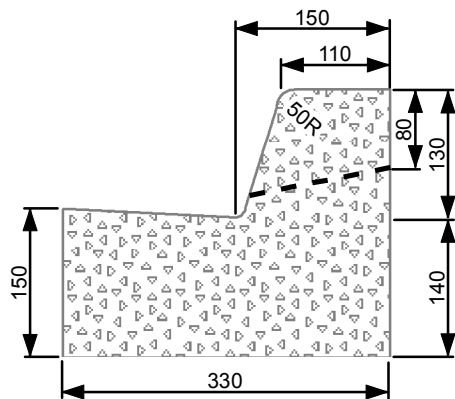

TYPE "A"

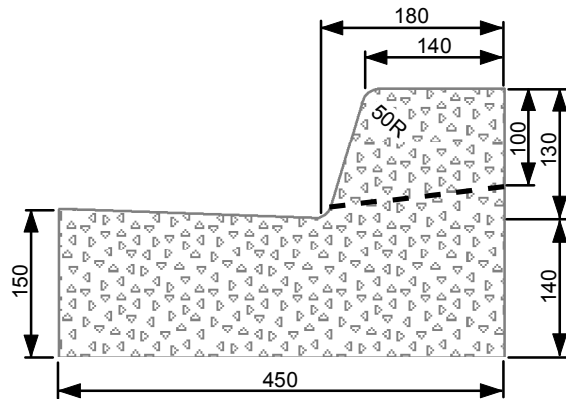

TYPE "B"

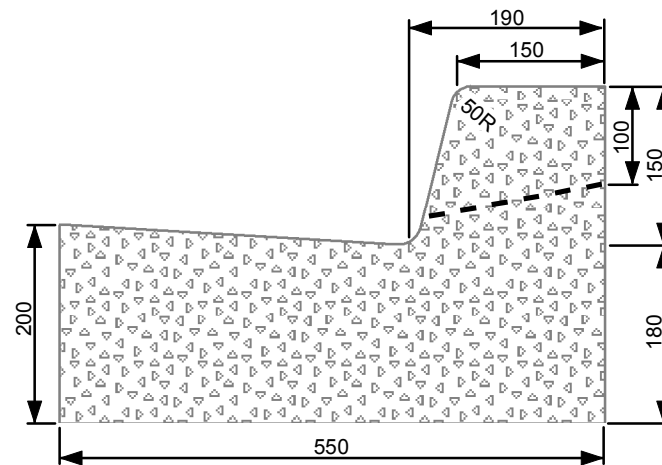

TYPE "C"

ALL DIMENSIONS ARE IN MILLIMETRES.

NOTES:

- 1 CURBS AND CURB AND GUTTER SHALL BE BUILT ON AN APPROVED GRANULAR BASE HAVING A MINIMUM DEPTH OF 150 mm.
- 2 EXPOSED EDGES SHALL BE FINISHED WITH A ROUNDED TOOL TO PRODUCE A 23 mm RADIUS OR AS SHOWN.

<p>TOWN OF YARMOUTH ENGINEERING AND PUBLIC WORKS DEPARTMENT</p>	
<p>STANDARD DRAWING</p>	
<p>CONCRETE CURB & GUTTER DETAIL</p>	
<p>Drawn By: T Bruce</p>	
<p>Approved By:</p>	<p>Date: July 08, 2015</p>
<p>DRAWING #3</p>	

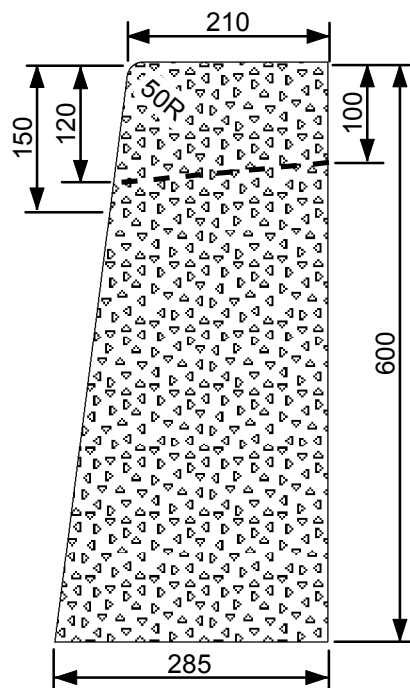

TYPE "D"

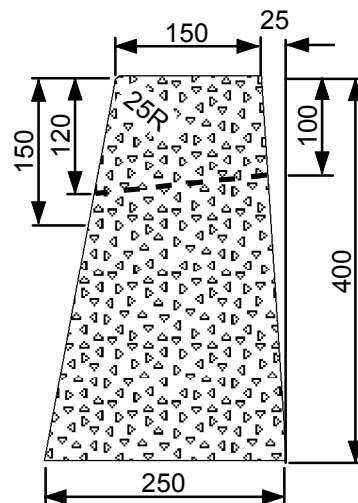

TYPE "E"

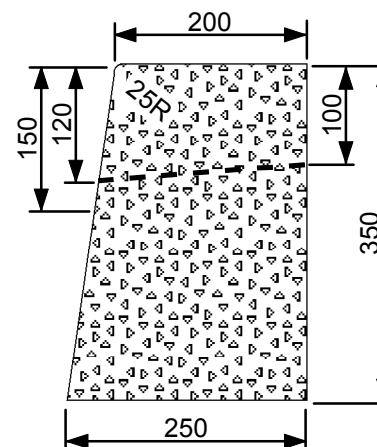

TYPE "F"

ALL DIMENSIONS ARE IN MILLIMETRES.

NOTES:

- 1 CURBS AND CURB AND GUTTER SHALL BE BUILT ON AN APPROVED GRANULAR BASE HAVING A MINIMUM DEPTH OF 150 mm.
- 2 EXPOSED EDGES SHALL BE FINISHED WITH A ROUNDED TOOL TO PRODUCE A 23 mm RADIUS OR AS SHOWN.

TOWN OF YARMOUTH ENGINEERING AND PUBLIC WORKS DEPARTMENT		
STANDARD DRAWING		
CONCRETE CURB DETAIL		
Drawn By: T Bruce		Date: July 8, 2015
Approved By:		DRAWING #4

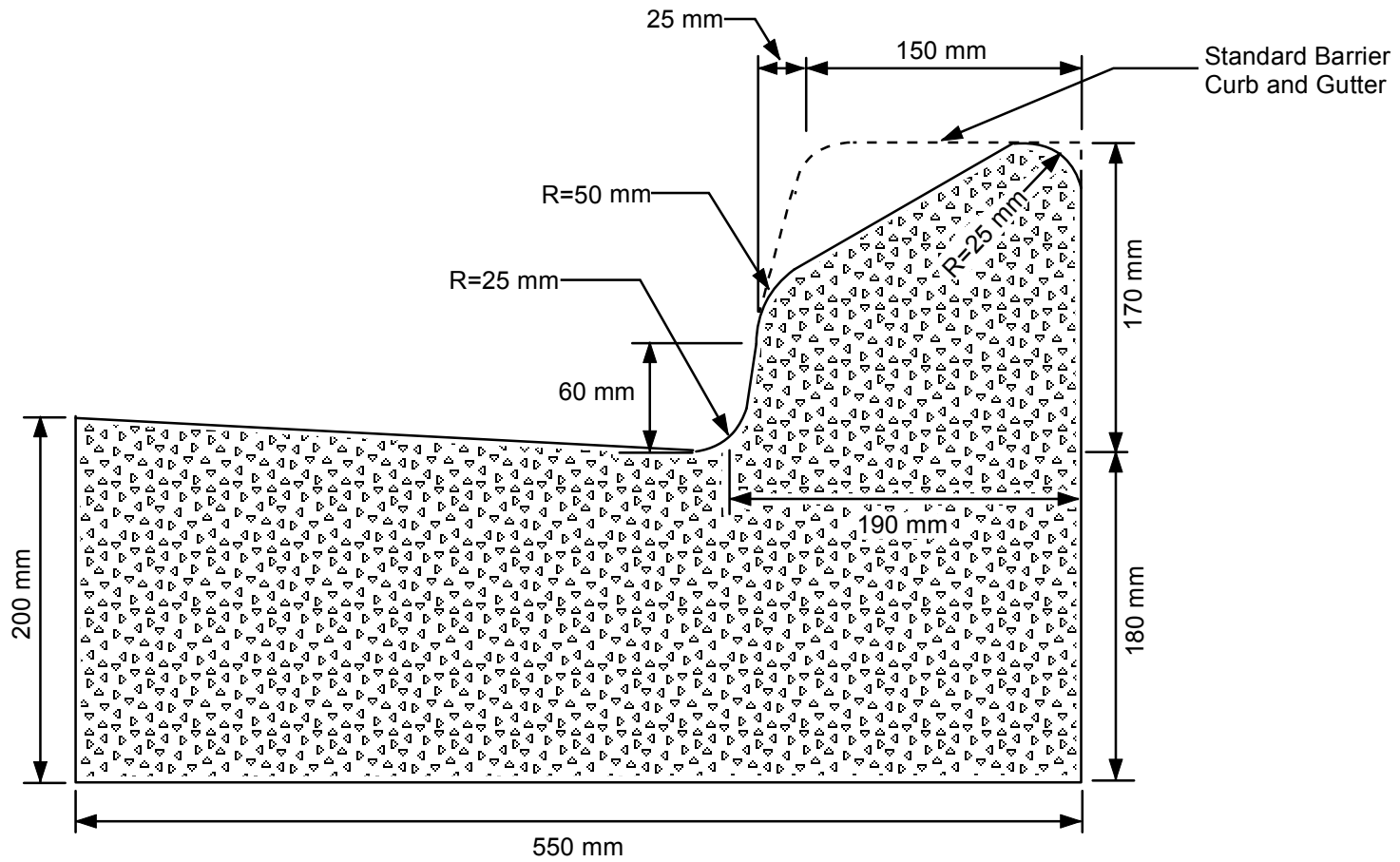

TOWN OF YARMOUTH ENGINEERING AND PUBLIC WORKS DEPARTMENT		
STANDARD DRAWING		
SEMI-MOUNTABLE CURB & GUTTER		
Drawn By: T Bruce		Date: April 26, 2010
Approved By:		DRAWING #8

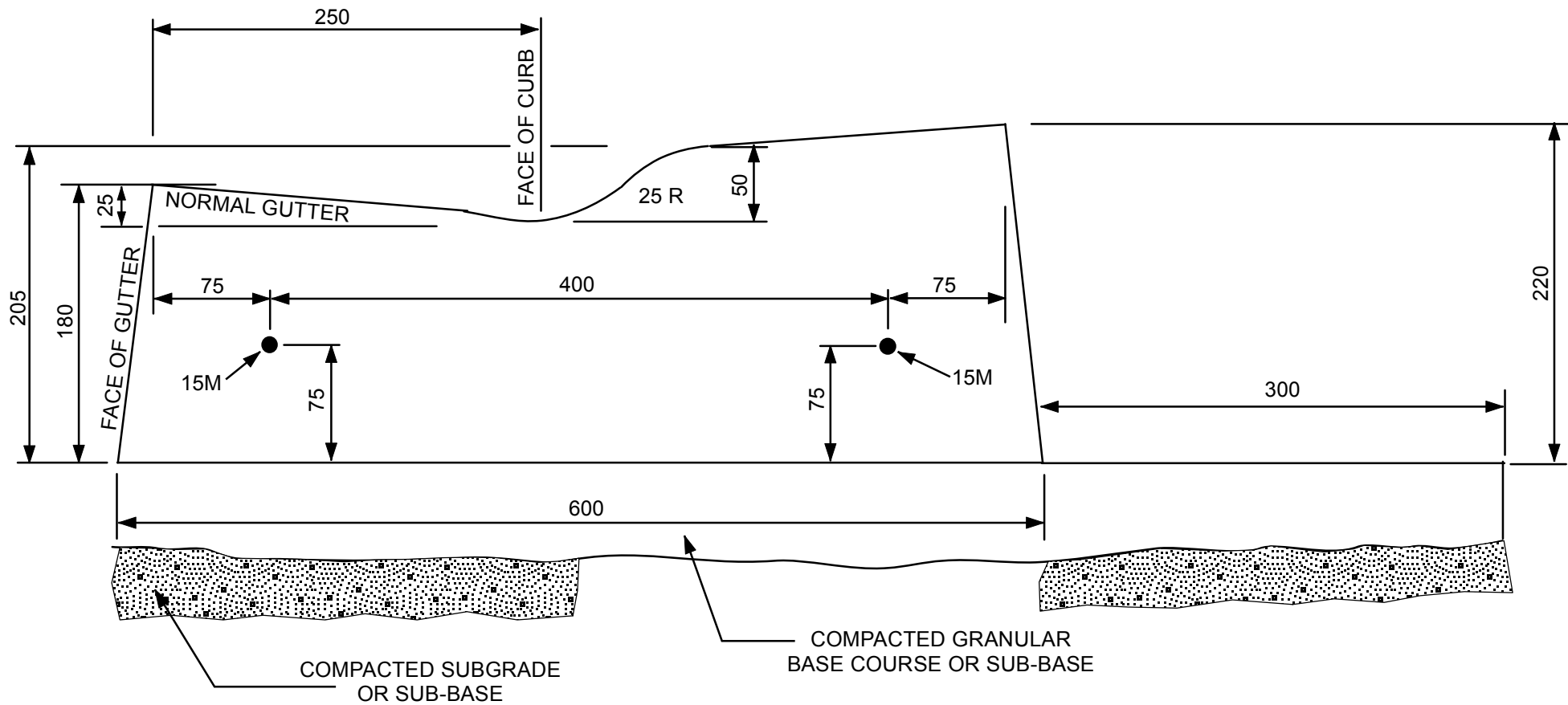

DRIVEWAY SECTION

NOTE

1. ALL DIMENSIONS ARE IN MILLIMETRES
2. REINFORCEMENT NOT REQUIRED AT PRIVATE CROSSING

TOWN OF YARMOUTH ENGINEERING AND PUBLIC WORKS DEPARTMENT	
STANDARD DRAWING	
ROLLED CURB & GUTTER, DRIVEWAY CROSSING DETAILS	
Drawn By: T Bruce	
Approved By:	
Date: April 26, 2010	
DRAWING#9(b)	

CROSS-SECTION

DRAWING #1

1.2 m WIDE x 100 mm THICK CONCRETE SIDEWALK

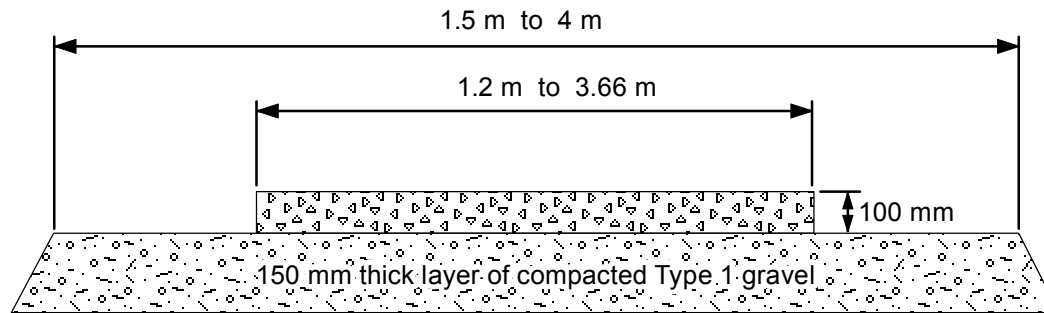

DRAWING #2

1.2 m - 150 mm WIDE SIDEWALK - CURB COMBINATION

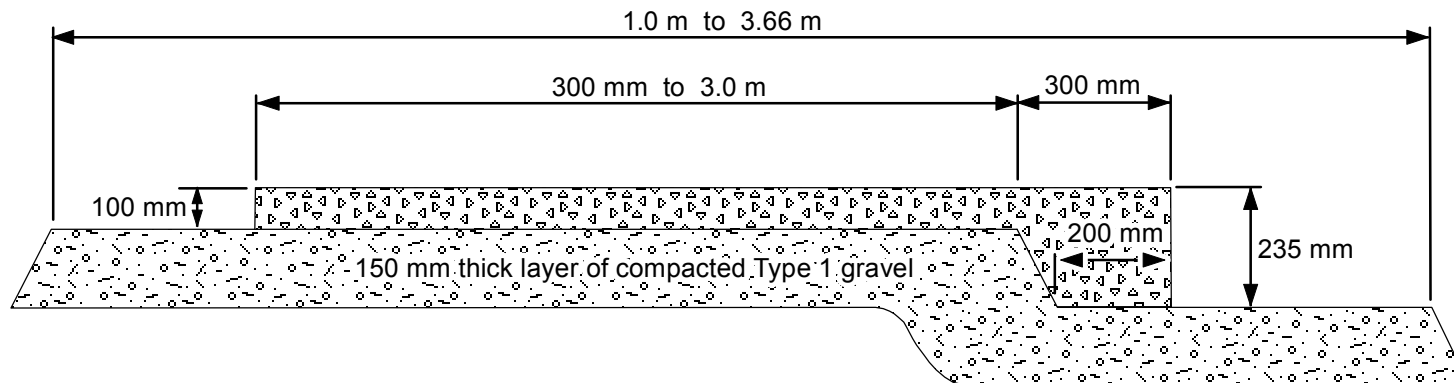

NOTE:

1. ALL EXPOSED CORNERS SHALL BE EDGED.
2. ALL WALKS SHALL BE SLOPED 1/4" PER LINEAL FOOT TOWARD THE STREET.

TOWN OF YARMOUTH ENGINEERING AND PUBLIC WORKS DEPARTMENT		
STANDARD DRAWING		
CONCRETE SIDEWALK AND CURB COMBINATION		
Drawn By: T Bruce		Date: June 16, 2014
Approved By:		DRAWING #15

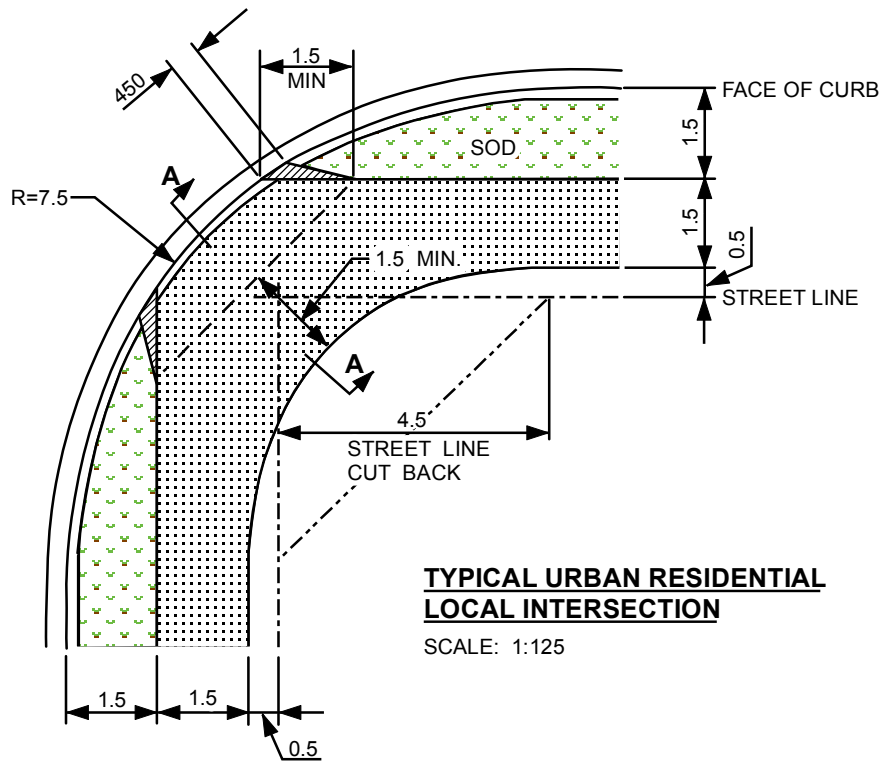

TYPICAL URBAN RESIDENTIAL LOCAL INTERSECTION

SCALE: 1:125

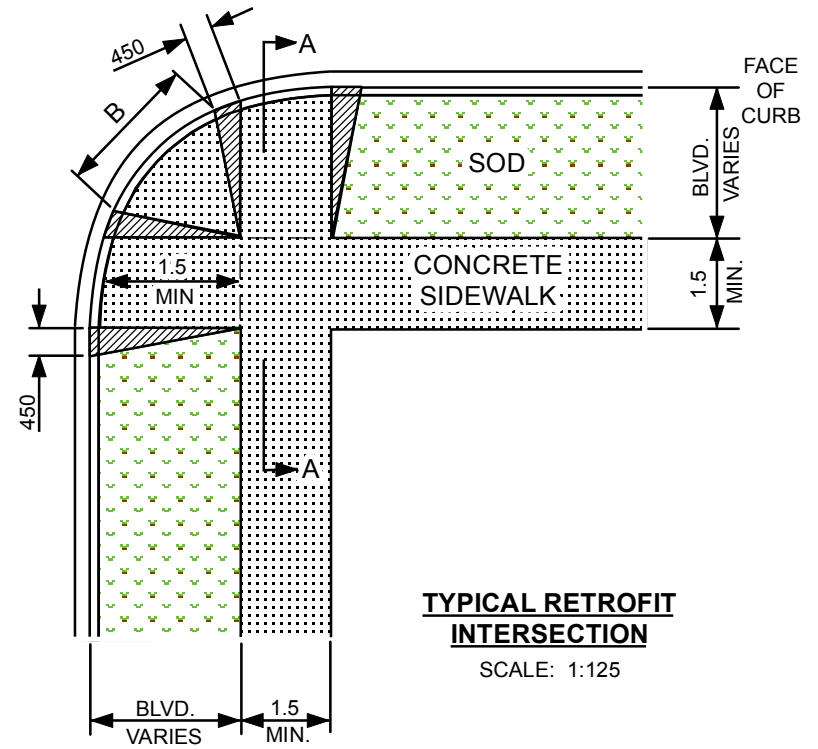

TYPICAL RETROFIT INTERSECTION

SCALE: 1:125

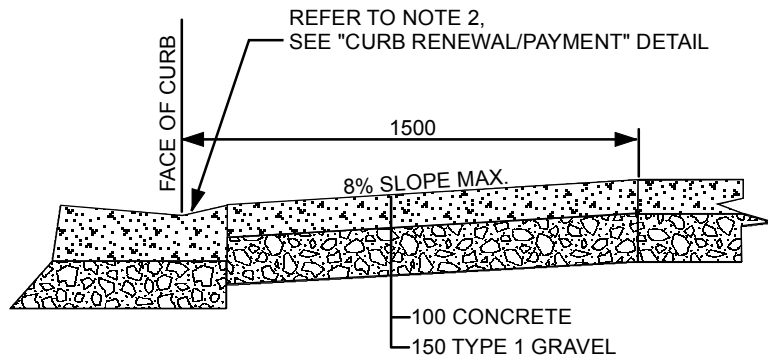

SECTION 'A' - 'A'

SCALE: 1:25

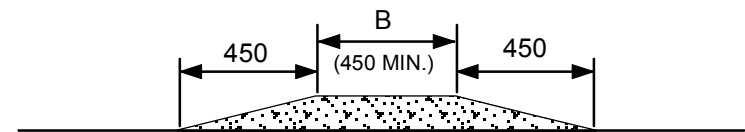

PEDESTRIAN RAMP DIVIDER VIEW

SCALE: 1:25

NOTES:

1. PEDESTRIAN RAMPS SHALL BE ALIGNED WITH THE SIDEWALK INSIDE EDGE.
2. INSTALL RAMP DIVIDER ONLY WHEN (B) WILL BE GREATER THAN 450mm.
3. WHERE RAMP DIVIDER IS NOT POSSIBLE, THE MINIMUM WIDTH OF RAMP IS TO BE THE RESULTING WIDTH IF RAMP EDGES ARE ALIGNED WITH INSIDE EDGES OF SIDEWALK. MINIMUM RAMP WIDTH IS 1.5m.
4. WHERE THE SIDEWALK ABUTS THE CURB A 1.0m TRANSITION TAPER IS REQUIRED IN THE CURB AND SIDEWALK ALONG ITS LENGTH.

TOWN OF YARMOUTH ENGINEERING AND PUBLIC WORKS DEPARTMENT	
STANDARD DRAWING	
PEDESTRIAN RAMP ALIGNMENT	
Drawn By: T Bruce	
Approved By:	
Date: May 29, 2014	
DRAWING #16	

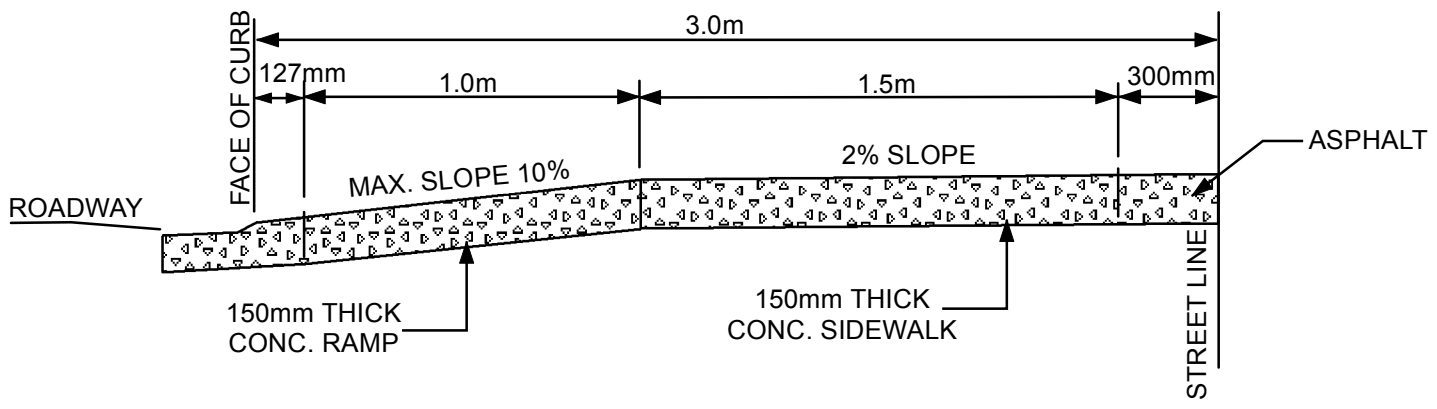
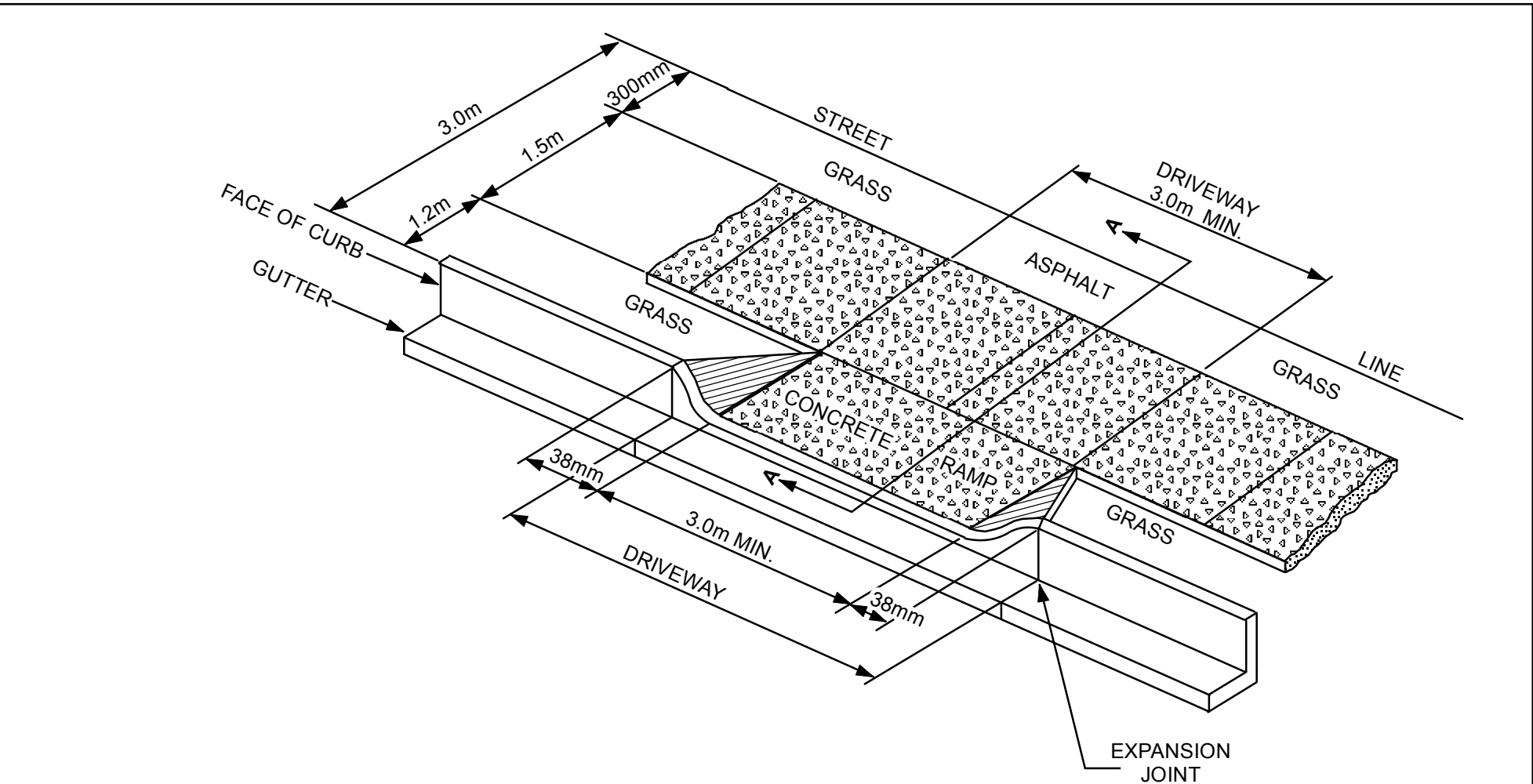

SECTION 'A' - 'A'

NOTE:
PEDESTRIAN RAMPS SHALL HAVE
EXPOSED AGGREGATE FINISH.

TOWN OF YARMOUTH ENGINEERING AND PUBLIC WORKS DEPARTMENT	
STANDARD DRAWING TYPICAL CONCRETE DRIVEWAY RAMP - CROSS - SECTION AND PLAN -	
Drawn By: T Bruce	
Approved By:	
Date: June 9, 2014	
DRAWING #17	

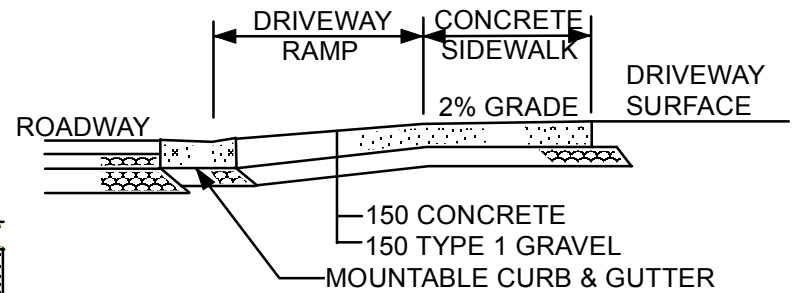
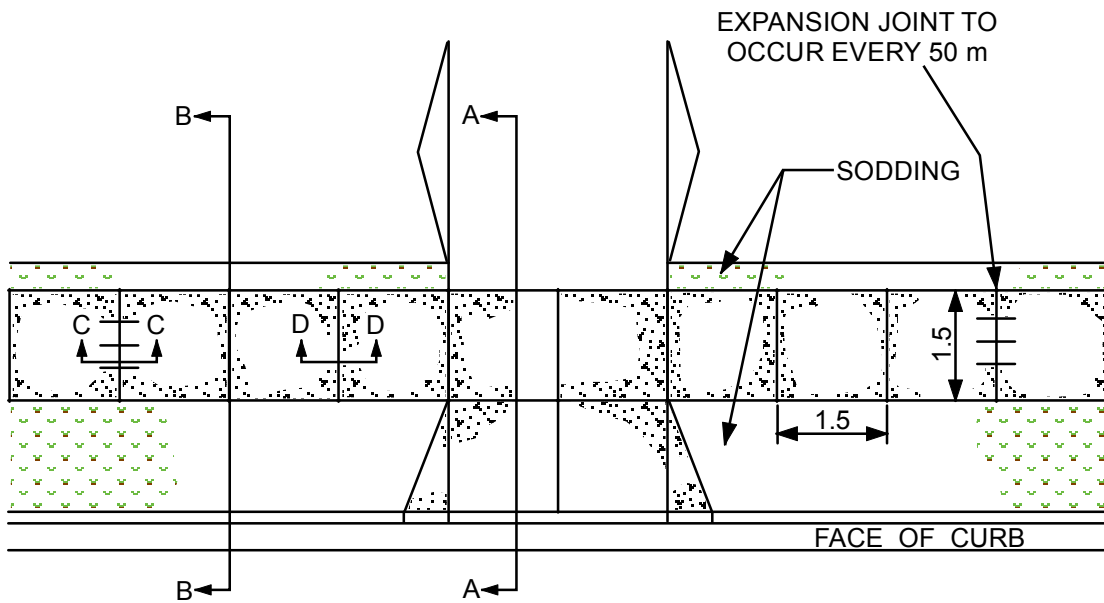

SECTION A - A
(DRIVEWAY CROSS-SECTION)

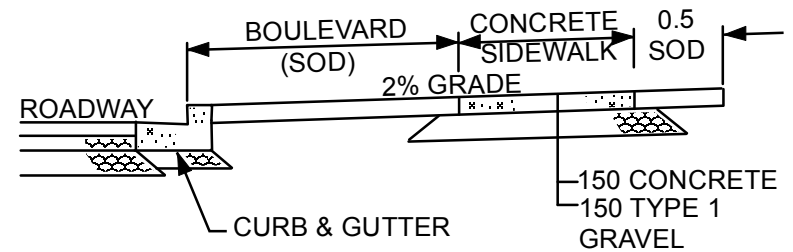

SECTION B - B
(SIDEWALK CROSS-SECTION)

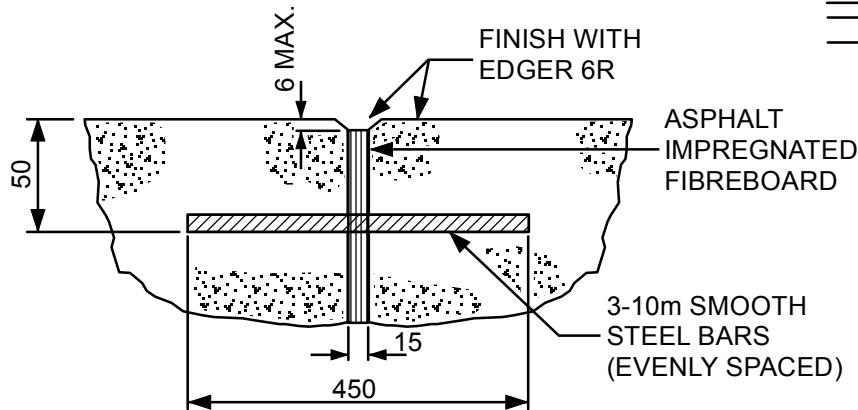

SECTION C - C
(EXPANSION JOINT)

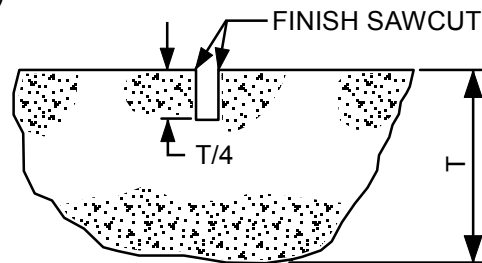

SECTION D - D
(CONTROL JOINT)

NOTE:

1. CONCRETE SIDEWALK AT COMMERCIAL DRIVEWAY TO BE 150 THICK WITH 150X150 WELDED WIRE MESH.
2. CRUSHED ROCK BASE TO EXTEND 150 BEYOND EDGE OF SIDEWALK STRUCTURE.
3. CONTROL JOINTS ARE TO BE SAW CUT.
4. SIDEWALK ABUTTING HIGH DENSITY AREAS SHALL HAVE FULL WIDTH (3 m) SIDEWALKS.
5. SIDEWALKS ABUTTING COMMERCIAL AREAS ARE TO BE FULL WIDTH (3 m) AND 150 MM THICKNESS.
6. EXPANSION JOINT BARS ARE TO BE GREASED ON ONE SIDE OF THE JOINT.
7. DURING CONSECUTIVE POURS, THE END OF EACH POUR IS TO OCCUR AT AN EXPANSION JOINT. WHERE THIS IS NOT FEASIBLE, AN ADDITIONAL EXPANSION JOINT IS TO BE INSTALLED.
8. INSTALL A 9 m LONG CONCRETE LANDING PAD AT ALL BUS STOP LOCATIONS. INCREASE THIS TO 14.5 m FOR ARTICULATED BUS ROUTES.
9. WHEN BOULEVARD IS LESS THAN 1.5 m OR WHEN THE SIDEWALK ABUTS THE CURB & GUTTER, SLOPE SIDEWALK AND DRIVEWAY RAMP IN A STRAIGHT LINE GRADE FROM BACK OF SIDEWALK TO LIP ON CURB OPENING.

TOWN OF YARMOUTH		
ENGINEERING AND PUBLIC WORKS DEPARTMENT		
STANDARD DRAWING		
URBAN SIDEWALK		
Drawn By: T Bruce		Date: June 12, 2014
Approved By:		DRAWING #18